

REEFER UNIT SPECIFICATIONS

1. built-in refrigeration system that saves cargo space
2. energy-saving technology guarantees maximum refrigeration capacity

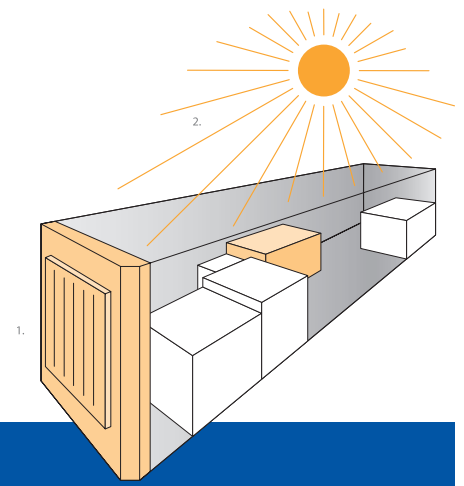

DIESEL-ELECTRIC REFRIGERATED CONTAINER

external dimensions

length: 13716 mm
width: 2556 mm
height: 2896 mm

internal dimensions

length: 13233 mm
width: 2437 mm
height: 2575 mm
(first row pallets
max. 1590mm)

door opening

door width: 2436 mm
door height: 2540 mm

capacity

80 m ³	europallet (1200mm x 800mm)	33
	iso pallet (1200mm x 1000mm)	26

ratings

max. gross weight: 34000 kgs

tare weight: 7445 kgs
(incl. cooling unit
and full fuel tank)

max. payload: 26555 kgs

capacity fuel tank: 800 ltr

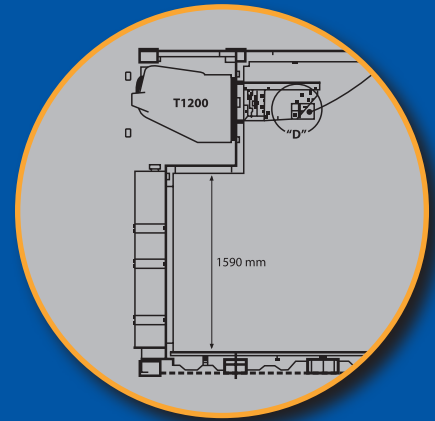

- ADVANCED TRACK & TRACE SYSTEM WITH SENSOR
- SPECIAL AIR DUCT SYSTEM
- OPTIONAL LASHING EYES IN THE SIDE WALLS
- OPTIONAL DOUBLE STACK SYSTEM