

# REEFER UNIT SPECIFICATIONS

1. built-in refrigeration system that saves cargo space
2. energy-saving technology guarantees maximum refrigeration capacity

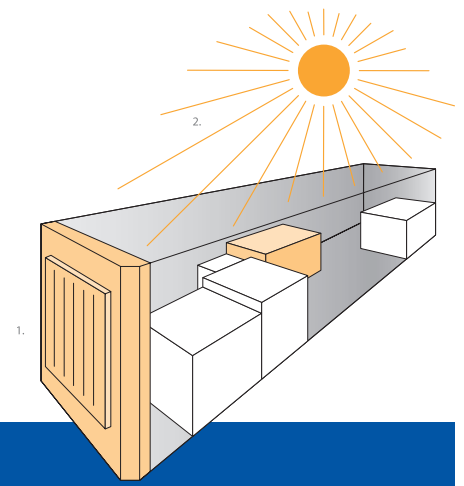

## DIESEL-ELECTRIC REFRIGERATED CONTAINER

### external dimensions

length: 13716 mm  
width: 2556 mm  
height: 2896 mm

### internal dimensions

length: 13233 mm  
width: 2437 mm  
height: 2575 mm  
(first row pallets  
max. 1590mm)

### door opening

door width: 2436 mm  
door height: 2540 mm

### capacity

80 m<sup>3</sup> europallet (1200mm x 800mm) 33  
iso pallet (1200mm x 1000mm) 26

### ratings

max. gross weight: 34000 kgs

tare weight: 7445 kgs  
(incl. cooling unit  
and full fuel tank)

max. payload: 26555 kgs

capacity fuel tank: 800 ltr

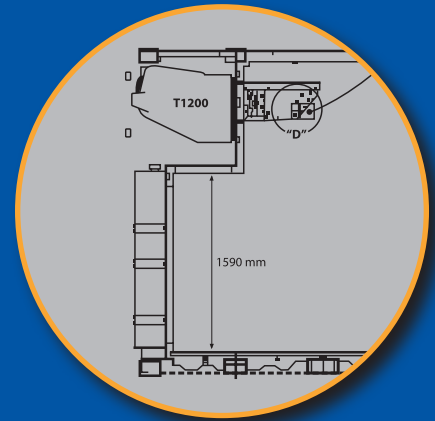

- ADVANCED TRACK & TRACE SYSTEM WITH SENSOR
- SPECIAL AIR DUCT SYSTEM
- OPTIONAL LASHING EYES IN THE SIDE WALLS
- OPTIONAL DOUBLE STACK SYSTEM